

OMICRON TWIN 21300(H) PN25 316L (stacked configuration)

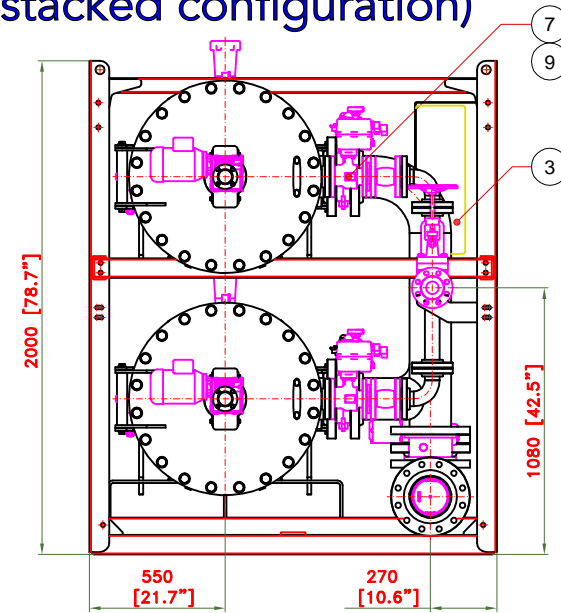

ITEM	LINE	CONNEXION
A	RAW WATER INLET	6\"-300# ANSI
B	FILTERED WATER OUTLET	6\"-300# ANSI
C	BACKWASH OUTLET	2\"-300# ANSI

Total length including all clearances: 4500 [177\"

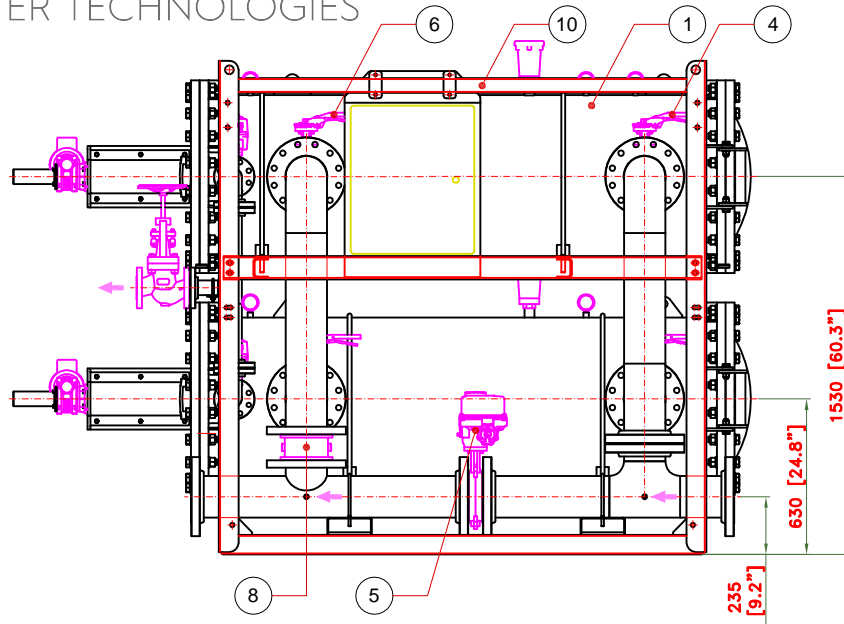
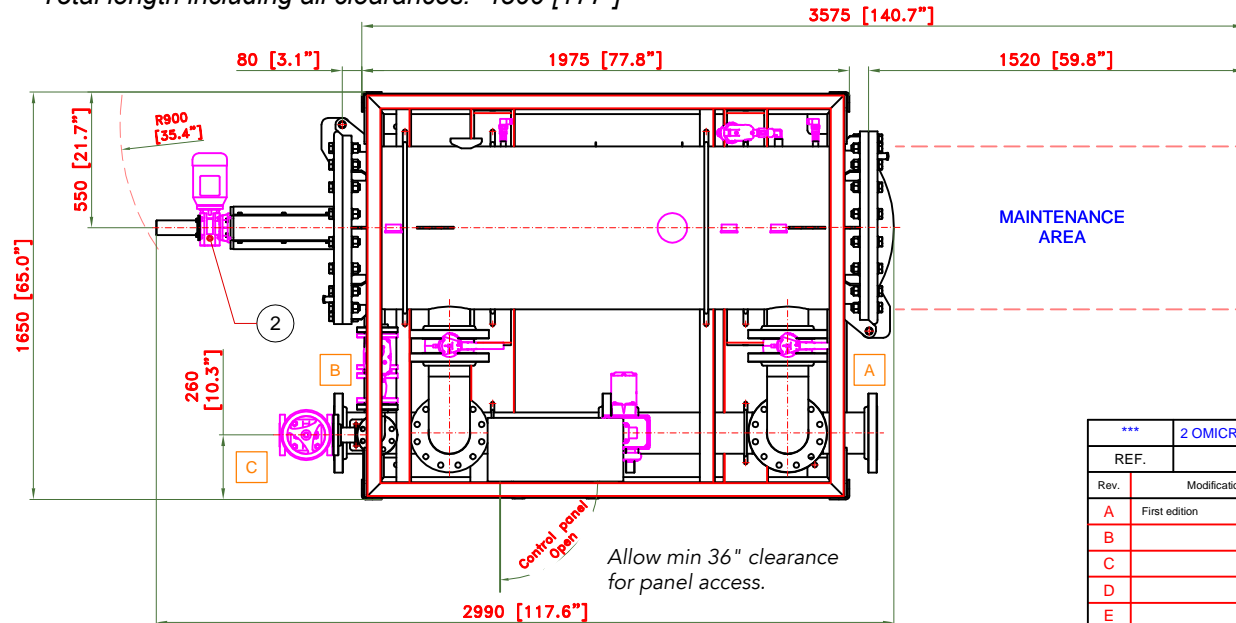

ITEM	DESIGNATION	QUANT.	MATERIAL	OBSERVATIONS
1	AUTOMATIC FILTER: FMA-2014 WITH INLET / OULET NOZZLES 6\"-300lbs	2	AISI-316L	
2	ELECTRIC MOTOR	2	...	
3	CONTROL PANEL DIMENSIONS: 600 x 500 x 200	1	...	
4	WAFER BUTTERFLY VALVE 6\"- 300 Lbs	2	IRON CAST AISI-316L DISC	RAW WATER INLET
5	WAFER BUTTERFLY VALVE 6\"- 300 Lbs	1	IRON CAST AISI-316L DISC	BY-PASS
6	WAFER BUTTERFLY VALVE 6\"- 300 Lbs	2	IRON CAST AISI-316L DISC	FILTERED WATER OUTLET
7	ELECTRIC BACKWASH VALVE 2\" L = 150 - FLANGED	2	AISI-316L	BACKWASH OUTLET
8	WAFER CHECK VALVE 6\"- 300 Lbs L = 106	1	AISI-316L	
9	RUBBER EXPANSION JOINT 2\"- 300 Lbs L = 130 - FLANGED	2	EPDM	
10	SKID	1	S-275-JR	

REF.	ITEM	QUANTITY	MATERIAL	WEIGHT	OBSERVATIONS
***	2 OMICRON 21300 WITH MANIFOLDS	1	STAINLESS STEEL	***	***
Rev.	Modification	Date	Name	Signed	CLIENT: OMICRON WATER TECHNOLOGIES
A	First edition	01/09/21	J.P.R.	<i>J.P.R.</i>	Scale: 1:21
B					REFERENCE: ***
C					Format: A3
D					DESCRIPTION: OMICRON TWIN 21300(H)
E					Date: 01/1X/21
F					Name: J.P.R. <i>J.P.R.</i>
	WORK ORDER: 71xxx	N° DRAWING: 21.71xxx.00.00	Projection:	Reviewed: 01/1X/21	J.P.R. <i>J.P.R.</i>
				Approved:	



Control panel open
Allow min 36" clearance for panel access.